



• THE •
PIANOLA
JOURNAL

The Journal of the Pianola Institute

No. 6 1993

A Ramble on the Duo-Art Theme: Patrick Handscombe

The Reproducing Piano (parts 1 and 2): John Farmer

The Player Piano on Record - a discography (part 4):

Denis Hall

Rachmaninov's Russia and a Stravinsky Première:

Robert Matthew-Walker

Recent Piano Roll Issues: Dan Wilson

Contents

Editorial	3
A Ramble on the Duo-Art Theme: Patrick Handscombe	5
The Reproducing Piano (Introduction, parts 1 and 2): John Farmer	18
The Player Piano on Record - a discography (part 4): Denis Hall	40
Reviews:	
Rachmaninov's Russia and a Stravinsky Première: Robert Matthew-Walker	45
Recent Piano Roll Issues: Dan Wilson	47
Notes on Contributors	52

© The Pianola Institute 1993
All rights reserved

British Library Cataloguing in Publication Data
The Pianola Journal — Vol.6 -

1. Player-piano — Periodicals
I. Pianola Institute
789'.72ML 1070

ISBN 0952-6323

The Pianola Journal is published by the Pianola Institute Ltd, registered office, 111a Station Road, West Wickham, Kent. Registered in England number 1937014. Registered Charity number 292727.

The aims of the Institute

A small number of pianola owners and musicians have been concerned for some time at the unnatural break between the world of music rolls and the world of music. Few members of the musical public know much about player pianos, and the Institute aims to bring about a better understanding and appreciation of the instrument in a number of ways.

Plans have been made for a regular journal, public concerts, a lending library of rolls, a travelling exhibition, and in addition, a roll and information archive is to be established, with a small collection of player pianos for listening and study purposes.

The Pianola Institute will endeavour to preserve, research and document the pianola's history, to improve the instrument's present standing, and by the commissioning of new compositions, to ensure that it remains an important musical force for the future.

The Directors of the Institute are:

Hugo Cole, Louis Cyr, Keith Daniels, Mike Davies, Denis Hall, Rex Lawson, Donna McDonald. Company Secretary: Claire L'Enfant.

The Patron of the Institute is Conlon Nancarrow.

It is possible to support the work of the Institute by joining the Friends of the Pianola Institute. Membership enquiries should be sent to Mike Davies, 9 Jillian Close, Chestnut Avenue, Hampton, Middlesex, England.

For 1993-94, subscriptions, which include postage and packing, are as follows:

£10 for individual subscriptions in the UK

£15 for individual subscriptions overseas

£15 for institutional subscriptions in the UK

£20 for institutional subscriptions overseas

Overseas subscriptions should be made payable in sterling. The fee includes a subscription to the journal and details of the activities of the Institute.

Editorial

When this Institute was founded (and it will soon be ten years since the process was set in motion), there was a general feeling that foot-operated player-pianos were regarded mainly as interesting mechanical devices which rather incidentally happened to produce music. This was in some contrast with reproducing pianos, which were already being taken seriously by the public after something of a dark age during and after the Second World War. Articles such as John Farmer's essay on the Ampico, recordings of both his and Norman Evans' instruments, and public concerts in London had restored the reputation of recorded rolls in Great Britain, while similar recordings of Welte and Duo-Art pianos had produced equal effect overseas. We are therefore very pleased to have been accorded permission to reproduce John Farmer's writings, specially revised by him, and taken from the Journal of the British Institute of Recorded Sound (now the National Sound Archive). They will be continued in the 1994 Pianola Journal.

In recent months an extended theoretical discussion of the Duo-Art has been privately published by Harry Stephenson in the Isle of Man. We are in something of a quandary over how to react in these pages, since our editorial board collectively and profoundly disagrees with many of his findings and bases for them. A review was commenced, but in the relatively small world of player-pianos we preferred to publish positive opinions rather than negative criticism. Consequently we include Patrick Handscombe's article on Duo-Art theory and hope that those interested in the subject may care to react with correspondence.

Attitudes to reproducing pianos have perhaps matured, but not greatly changed, while the Institute has been in existence, but the pianola provides a considerable contrast. No doubt much of the enthusiasm felt by collectors around the world is still based on a love of suction pumps, belt drives, ingenious pneumatic valves and shining brass on polished wood. Quite right too! But a change has slowly occurred in the past ten years, and it may be as well to note it in these columns, since it is not always easy to recognize on an everyday basis.

Where there were once two or three pianolists to be found on the concert platform, there are now a good dozen or more to be heard (and seen!), and in several countries of the world. Rein Groos in Holland takes the laurels for being the only one to have performed in North Africa, while others have visited both America and the continent of Europe, and we especially welcome Wolfgang Heisig of Dresden, able to perform more widely as a result of the unification of Germany.

4 Editorial

There are of course no standards set for pianolists; no Royal College of Music qualifications that demand expertise on the instrument, so that the only necessity for public performance is an accessible concert hall and a portable pianola. It is to be hoped that such standards may one day be set, and for pianola and reproducing piano repairers as well. In the meantime the quality and quantity of new music rolls has continued to improve, as our reviewer, Dan Wilson, points out in characteristic fashion. We have included addresses for the roll companies that he mentions since such information is often difficult to find, and we are pleased to note the enterprise of all involved.

Denis Hall, whose annual discographies have hitherto covered only the reproducing piano, ends his current series with a look at the rather small number of serious pianola performances available on record. Perhaps it will take the next ten years to see an improvement on this scarce situation.

Our editorial should not pass without mention of the fact that the Pianola Institute and AMICA, the Automatic Musical Instrument Collectors' Association of America, have officially recognized each other as sister societies. AMICA now includes a pianola-playing competition (a pumper contest) at its annual conventions, a development we note with enthusiastic approval.

A Ramble on the Duo-Art Theme

Patrick Handscombe

We know from at least one source¹ that the American Aeolian Company was stung into offering a reproducing piano system of its own following the enormous success of the German Welte-Mignon in the United States from about 1905.

Reproducing systems are distinguished particularly by their ability to emulate accurately – or at least convincingly – the recording pianist's original dynamics. We can be sure that a company of the size and prestige of Aeolian – maker of the famous Pianola and the world's largest player-piano manufacturer – would have used every resource to produce the finest practicable system, and as soon as possible. Even so, development took about seven years, which disproves the suggestion that it was a hasty contrivance, and the Duo-Art, 'that is, representing two arts – the art of the performer and the art of the interpreting pianist'² was launched in the Autumn of 1913.

At present we know virtually nothing of the Duo-Art's actual designers. However we can be fairly certain that the inventor of the original pianola, E. S. Votey, was involved: he was apparently Aeolian's Technical Director when he visited the company's London branch in about 1919 or 1920.³ Another may have been J. W. Crooks, inventor in 1900 (following E. M. Skinner of the Aeolian-Skinner Organ Company) of the Themodist accenting device [fig.1] which was retained as the basis of the Duo-Art.

Doubtless a significant proportion of the development period was occupied in devising and mastering the recording part of the system and in polishing the first rolls for its début, and it is likely that the Duo-Art's first recording producer and engineer W. Creary Woods was responsible for much of this.

Aeolian, like similar companies, sought the fullest patent protection for its products. No one patent is found for the Duo-Art as it finally appeared however, because rather than risk pre-emption by competitors, applications were filed on individual components at the earliest opportunity – which allows some insight into the development process – and were intentionally written in such a way as to divert attention from their real significance. Three successive patents⁴ are found which reveal all but one of the Duo-Art dynamic control mechanism's four essential components.

6 *A Ramble on the Duo-Art Theme*

The first appeared very early: it is No. 4092 dated 19 February 1906 and covers the dynamic accordion pneumatic [fig.2]. As described and illustrated the device is logically capable of sixteen positions, as in the final Duo-Art, yet, misleadingly, only ten are alluded to.

The importance of this component cannot be over-emphasized, as it enables sufficient instantaneous dynamic levels for accurate reproduction to be derived from the roll using only four tracker bar ports, and maintains perfect dynamic-to-note synchronism irrespective of roll speed, which is not the case in systems with externally-timed crescendo/decrescendo devices triggered from the roll, such as the Ampico. Today the accordion pneumatic is recognized as a four bit binary to decimal decoder, and is essentially a digital data expansion mechanism. In 1906 binary digital coding was being considered only in mathematics, cryptography and telegraphy, which makes its adoption very advanced. Modern reproducing pianos such as those by Yamaha and Bösendorfer use electronic binary digital code.

The second patent is No. 146 of 2 January 1908 which shows for the first time the double-ended knife valve regulator and an improved form of the Themodist system [fig.3]. Ostensibly they constitute a manually operated expression mechanism and no reference is made to automatic control. The knife valve is impressive for its simplicity and ease of construction while combining control and governor functions in one unit and making use of inherent variable frictional damping. It is in fact a high input impedance pneumatic amplifier with integral feedback, which can effect large changes in vacuum without variations in the controlling force.

In patent No. 7684 of 29 March 1912 the combination of bass and treble theme mechanisms with theme and accompaniment knife valve regulators is revealed [fig.4]: this is none other than a fully automatic Themodist system, and J.W. Crooks's original patent is referred to [fig.1]. Retention of the Themodist conferred several significant advantages: its ability to accent a note or notes in an unbroken chord; instrument compatibility – Duo-Arts, unlike other reproducing systems, could play 88 note Standard and Themodist rolls; and it facilitated the quasi-real-time recording with immediate replay which was unique to the system.

However, knife valve control is by 'floating' pneumatics, much as in the Hupfeld Duo- and Tri-Phonola systems, but friction stabilized. It seems doubtful in retrospect that Aeolian intended to use this method, but the possibility was covered. The real coup was revealed soon after when the Duo-Art was launched: the substitution of two dynamic accordions, their steps interlaced, thus providing a total of thirty-two possible dynamic levels between theme and accompaniment.

Now, apparently, we have the complete Duo-Art dynamic control system [fig.5], which operates as follows: air from the bass and treble sections of the pneumatic note-playing 'stack' is normally exhausted by the electric pump via two non-return valves 21, 23, through the accompaniment knife valve, which is controlled by its dynamic accordion 3-6. This is controlled by ports 1A, 2A, 4A, 8A above the first to fourth note holes in the tracker bar (notes 1-4 and 85-88 are rendered inactive in Duo-Art mode). Any of sixteen desired dynamic levels may be immediately signalled, from pianissimo at power 0 to fortissimo at power 15, when the accordion is completely collapsed. Regulator feedback ensures that varying numbers of notes (up to certain maxima) at any given level are played with equal intensity.

Instantaneously, notes in the bass or treble can be accented by diverting air from either or both sections of the stack through the theme knife valve by means of the two secondary valves 16, 27, which are roll-operated by the Themodist ports B THEME and T THEME in the tracker bar. The theme knife valve is controlled as before by its own accordion 31-34, controlled by ports 1T, 2T, 4T, 8T, each theme step being half a degree louder than its equivalent in the accompaniment. The theme level may be as much higher than the accompaniment as necessary, but can never be lower. Theme regulator control of either or both stack sections may be momentary, or prolonged by a stream of Themodist perforations in the roll. (Themodist perforations are horizontal pairs, commonly called 'snake-bites'.)

When operating correctly the accordions can open or close fully in about one-fifth of a second, so relatively fast as well as gradual dynamic changes are possible using either alone.

This is an extremely flexible system, capable of finely graded dynamics and immense rapidity of accent because the Themodist principle of switching between two pre-set levels avoids the effects of regulator inertia experienced in other reproducing mechanisms. This allows not only isolated notes or complete chords to be easily and cleanly accented, even in fast or crowded passages, but also a note or notes within an unbroken chord.

To accomplish this the accented notes are played and 'themed' fractionally later than those in the accompaniment, whose level is reduced by a certain factor. This ensures that the piano hammers of all the notes reach their strings at the same time, but with different velocities and thus different intensities.

It is sometimes claimed that the two simultaneous dynamic levels which this system can generate are insufficient to emulate the chord shading

8 *A Ramble on the Duo-Art Theme*

produced by real pianists. However, correctly voiced Duo-Art instruments – and indeed many normal pianos – exhibit a ‘higher pitch precedence’ which confers a slight natural shading; and more significantly modern acoustics research explains the established effectiveness of the approach: the human auditory system is subject to the phenomenon of ‘masking’, whereby sounds more than a certain degree quieter than others at the same moment are not immediately experienced.⁵ Today, this property is utilized in the PASC and other coding algorithms which reduce the amount of data storage necessary on Digital Compact Cassette and Mini Disc.

A further phenomenon is also accounted for in the Duo-Art system design: the auditory system is more sensitive to intensity changes at low sound levels than at high. This is expressed as ‘the audibility curve’ and is paralleled by the Duo-Art’s response curve, as shown in fig.6, in which about twenty of the thirty-two steps control the lower half of the piano’s dynamic range. Note that variations in mechanism sizes and settings allow the response curve to be matched to instruments of different dynamic ranges, while the roll remains consistent; this is a perfectly rational approach analogous to playing the same CD through different speakers in different sized rooms.

The response curve is a function of the vacuum pump tension, the regulator pneumatic closing force characteristics, the regulator spring rate, the knife valve pivot to port relationship and the knife valve linkage velocity ratios. Unfortunately in many instruments the knife valve linkages and regulator springs have become deranged, the stack valve travel is too great and the pump tension insufficient through wear or maladjustment, so that the response curve is convex, the piano playing with little pianissimo gradation, much mezzoforte and no fortissimo contrast. It is this all too common state of affairs which has given the reproducing piano a bad name!

This is doubtless also the origin of the criticism that thirty-two steps – usually only sixteen are mentioned – are too few to give enough dynamic fidelity. It is worth remembering that Ampico stressed the importance of matching the audibility curve and based its system on only seven fixed intensities, albeit with smooth crescendo/decrescendos between. (Incidentally, the derivation of only seven intensities from three tracker ports is a curious and seriously inhibiting lapse by Stoddart, the Ampico’s inventor.)

This brings us to one of the most important details of the Duo-Art – the fourth essential component referred to before, and one whose significance is always overlooked: the atmosphere intake, or spill. This innocent-

looking valve may not have been patentable, but it is a subtle yet vital feature of the Duo-Art system which the writer is inclined to believe Aeolian wished to keep obscure.

The Duo-Art service manuals either barely refer to it, or imply that the sole function of the spill, operated by either knife valve linkage, is to 'relieve the pump from unnecessary strain' at low dynamic levels. Now, it is not the best way to achieve this while maintaining a steady vacuum level at which the regulators could operate optimally: the familiar automatic spring-regulated spill such as that found in Ampico pumps would have been more easily engineered and effective. So why the Duo-Art design?

First, increasing the pump tension in this way increases the effective concavity, height and steepness of both theme and accompaniment response curves. Aeolian must have intended this, and rather ambiguously the manuals do state that 'the object of this valve is to increase or decrease pump tension when needed and it is automatically controlled by the dynamic perforations in the music roll'.

Second, consider that in many Duo-Art rolls sequences occur when theme dynamic perforations are present, but no Themodist snake-bites. In the past these have been regarded as redundant perforations not removed during editing. However, it is clear that by closing the spill valve they raise the accompaniment dynamic level. Measurement has shown that with the spill finally closing as specified at power 10, each accompaniment level up to power 9 may be raised by a maximum of about one step by the theme dynamics. Ten 'sub-steps' are possible at power 0, reducing to one at power 9. Thus perhaps an additional fifty-five accompaniment dynamic levels are available where most needed. This is a form of 'time-sharing' which makes the fullest use of the theme dynamic code stream during the large proportion of time when no themed notes are present.

The Duo-Art roll editors were not obliged to make use of the sub-steps. In many cases they seem to have worked empirically, adding and subtracting normal theme and accompaniment steps until the performance sounded right, which automatically took the spill function into account. However, there are examples where theme dynamic modulation of the accompaniment is clearly deliberate. Significantly, up-dated Duo-Art mechanisms which have been built obviating the 'inefficient' spill valve are in every case unable to match the subtleties heard from a properly regulated original. It is interesting to note that Gordon Iles, the late Aeolian boffin, included a theme-to-accompaniment cross-bleed to mimic

10 *A Ramble on the Duo-Art Theme*

the spill function in his famous Gerald Stonehill robot, and a dynamics-controlled spill valve in an experimental double-Ampico-A type Duo-Art expression mechanism seen by the writer.

Properly rebuilt and regulated Duo-Arts can give lifelike, convincing performances. Unfortunately, few do, even when cared for by 'experts'. Worst of all, there are some *appalling* recordings available of Duo-Arts which patently do *not* reproduce. With reproducing pianos particularly we should insist that fascination with their delightful mechanisms does not preclude critical, musical, informed assessment of their performance, and that patient rediscovery of the techniques required to make them perform correctly is not neglected in an understandable desire to 'get them working'.

Here are some strictures to be observed when fettling any Duo-Art:

- Before any rebuilding is started its original voicing, action and stack characteristics should be determined as far as possible.
- The piano itself must be in fine condition and properly regulated for good performance to be achieved. Some instruments – for instance those with stack pneumatics of different sizes – should perhaps be evenly regulated, while others should have progressive regulation from bass to treble. Here the services of an expert piano technician are essential.
- The transmission brakes, wind motor and governor must be correctly set up so that roll speed is constant, showing no cyclical fluctuations or hesitation which would distort the pianist's recorded rhythms.
- Both piano pedal mechanisms must operate quietly and – especially the sustaining pedal – fast enough to reproduce the briefest movements.
- All the stack pneumatics and pouches must be supple and in good condition, and the stack itself must be *airtight*, contrary to some opinion, to achieve the proper response curve, prompt repetition and even, soft playing – especially of chords. The knife valve regulators are designed to deal with the stack internal capacity and air from the pneumatics and bleeds of played notes only. For this reason the correct travel of the stack valves is *vital* if they are not to act as excessive in-leaks when in motion. Experience has shown that Duo-Art valve travel must be 0.020–0.030 ins. (0.50–0.75 mm). Shrinkage and compression of the suede valve faces cause the clearance to increase, and this must be allowed for if the nap has been brushed up during cleaning. Insufficient travel prevents fortissimo playing and good general repetition. When travel is correct the Duo-Art will easily play as softly as any other reproducing system.

Now, to achieve the correct response curve the accordions must be set up and matched to have exactly 15/16" total travel in perfect 1/16"

increments; the pump tension be sufficient to produce reasonable fortissimos; the regulator springs be correct for the dynamic range of the piano and properly adjusted; and the knife valve and spill linkages all be in the correct relationships.

Both knife valve linkages must occupy identical angles, and the resultant effective opening of each valve be *least between steps 0 and 1, and greatest between steps 14 and 15*. If this correct accelerative motion is not established, the response curve will be insufficiently concave. The effective opening is not easy to determine, for the straight-edged knife describes a compound motion across its port – which may be circular in some expression boxes, rectangular with rounded ends in others – the regulator pneumatic re-closing the valve after each step. Reiterative vacuum (water-gauge) measurements and linkage adjustments are probably the easiest method of optimising the response curve.

The pump tension must be set high enough for the piano to play fortissimo as loudly as a live pianist; then appropriate regulator springs allow the full range of regulator movement, and therefore the response curve, to be applied over the whole dynamic range. The force produced by the regulator pneumatic (like all normal pneumatics) reduces as it closes against its coil spring, which has a linear rate, so an increasing rate of vacuum is necessary to re-close the valve, which steepens the curve. If there is more than minimal spring tension at power 0 the piano will not play pianissimo; if there is insufficient spring tension when fully extended at power 15 the response curve will become convex; if there is insufficient pump tension the curve will be flattened.

Unless the original regulator springs have been over-tightened and distorted, they are usually quite serviceable. It is sometimes found that the theme spring has a higher rate than the accompaniment, though theoretically both should be identical and step interlacing achieved by fractional increase of the theme knife valve minimum setting and sufficient pump tension. However, judicious adjustment of the theme spring can ensure that at all times the theme regulator pneumatic, and thus the theme level, is half a step above that of the accompaniment.

The Duo-Art dynamic control system is not fickle. It embodies well-known principles and when correctly assembled responds to regulation in a predictable manner. For any installation there is only a small range of adjustment within which the piano can correctly be said to reproduce: this is related entirely to its dynamic range. The minimum level should be very quiet – sufficient only to play pianissimo unhesitatingly and without missing. The pump tension is dictated by the regulator springs fitted, and

12 *A Ramble on the Duo-Art Theme*

must be as high as possible without the piano shouting. Then if the response curve is correct, soft playing will be well-controlled and the whole spectrum of dynamic colour will be present. Anything less is an insult to the pianist!

Regrettably, the recording and editing of Duo-Art rolls is too big and, at present, too little researched a subject to be examined in this article. However, the following rolls, which can withstand any comparison, illustrate amply the Duo-Art's astonishing proficiency, and suggest that of all the reproducing systems it is the best:

- 6410 Viennese Waltz No 1 (Gaertner/Friedman) pl. by Ignaz Friedman
- 6419 Viennese Waltz No 2 (Gaertner/Friedman) pl. by Ignaz Friedman
- 6820 Barberini's Minuet (arr. Bauer) pl. by Harold Bauer
- 6889 Two Etudes (Bortkiewicz) pl. by Carol Robinson
- 7379 Victor Herbert Medley pl. by Robert Armbruster
- 713430 Dancing Tambourine (Polla) pl. by Pauline Alpert
- 71497 On the Mall (Goldman) pl. by Leith and Addison

Notes

1. *Duo-Art Piano Music*, complete catalogue, Charles Davis Smith, 1987.
2. From article in *The Piano and Organ Purchaser's Guide for 1919*, quoted in *The Player Piano Treasury*, Vestal Press, New York 1961.
3. Reminiscence of C. Crump concerning his father, Aeolian technician L. W. Crump, to Rex Lawson 1983.
4. British Patents (in Assignees' or Agents' names) are quoted, from the *Abridgements of Specifications, Class 88(i) Musical Instruments, Automatic*, but (they) parallel US Patents.
- 5 Ref.: Zwicker-Feldtkeller Masking Curves.

Figure 1

Automatic instruments – The invention is described in connection with an apparatus for playing on keyboard instruments mechanically, and it consists of means for emphasizing any desired notes. The apparatus is operated by vacuum produced by a bellows, and is of ordinary construction, so far as the tracker-board, pneumatics, and other related parts are concerned. The vacuum in the wind-chest 19 of the pneumatics which operate the key mechanism is kept below that produced immediately by the bellows by means of a regulating-valve, but can be raised by throwing the wind-chest into direct communication with the bellows.

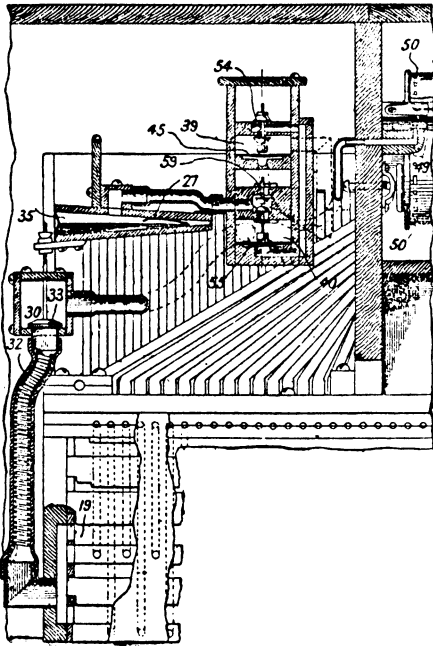

For this purpose the wind-chest 19, besides being connected with the ordinary supply, is connected by a pipe 32 with a chest 30, which is in turn connected with the part of the bellows in which the vacuum is produced, and in which the degree of exhaustion is greater than in the wind-chest 19 under normal conditions. The chest 30 contains a valve 33 which closes the pipe 32 and is operated by a pneumatic 35. This pneumatic is normally distended by a spring 27, so as to close the valve 33. The chest 30 is also connected to chambers 39 and 40, which are thus kept exhausted. Those notes which require emphasis have, besides their ordinary openings in the tune-sheet, at the edge additional ones 50 which

uncover holes 49 in the tracker board at the same time as, or just before, the other ones. This causes a diaphragm 45 to act upon a valve 54, which admits air to atmospheric pressure to a second diaphragm 55 through a passage 59. The diaphragm 55 operates another valve 59, which causes the pneumatic 35 to be exhausted, thus opening the valve 33.

Figure 2

Automatic instruments – Means for automatically actuating regulating-devices for modifying musical effects, or accenting notes, are shown in Fig. 1. The compound collapsible box 5 has four compartments 54, 55, 56, 57 of varying size, each compartment being connected by a pipe with a valve 31, controlled by one of four ports in the tracker-bar, which ports are additional to the ordinary playing ports. One or more of the

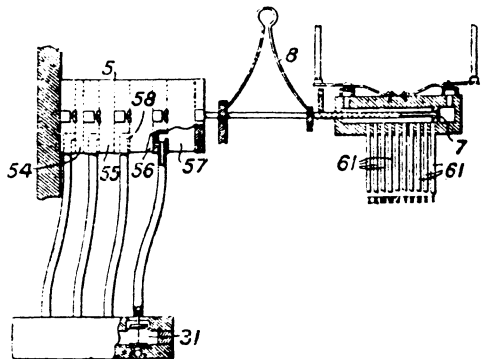

compartments 54, 55, 56, 57 may be collapsed to move the controlling-valve 7 into one of ten positions with respect to the accenting pipes 61. The spring 8 holds the box 5 in the expanded condition when it is not subject to suction. The tune-sheet has four or more controlling-perforations corresponding to the four or more control ducts and parts in the regulating-device. The pneumatic arrangement may be replaced by electrically-operated means in full or in part.

Figure 3

Automatic instruments - In automatic musical instruments, means are provided for varying the pressure actuating the playing mechanism by means of a valve having two adjustable points of support, one controlled pneumatically, and the other manually. As shown in Fig. 1, a finger-piece 1 is adapted for controlling two sections of the instrument, as for example, the bass and the treble. When it is desired to play more softly, a port, such as 2, is closed by the finger, and a chamber 9 becoming exhausted by means of the usual bleed hole, a valve 12 is depressed to connect a chamber 14 to the atmosphere, thus raising a valve 16 and closing a port 18. The air drawn from the motor pneumatics through a pipe 20 cannot therefore pass directly through a chamber 17 and tube 28 to the suction bellows, but swings a flap valve 23 to the position shown in dotted lines, and passes through a port 24, chamber 25, bellows 26, port 30, and duct 29, into the chamber 17 from below, and out through the tube 28. When the bellows 26 is fully distended, a valve 31 partly closes the port 30, and to compensate for any irregularities in the action of the pumping-bellows, a spring 27 is provided to expand the bellows 26 when the pressure falls, thereby keeping the pressure of the air acting on the motor pneumatics constant as long as the port 2 is closed. To reduce this pressure further, the finger-piece 1 is depressed, rocking an arm 35 through links 39, 37, 36, and thereby lifting an arm 34, to which the valve 31 is pivoted, so that the effective area of the port 30 is decreased. As there is only one finger-piece 1, the valves 31 for all the bellows 26 are connected to the shaft 35. Spring-pressed valves may be used for closing the ports 2, 3.

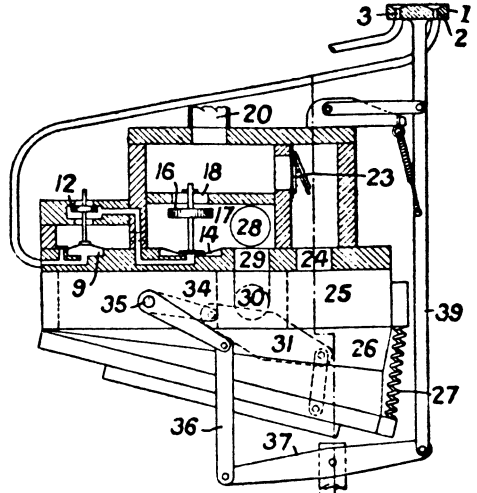
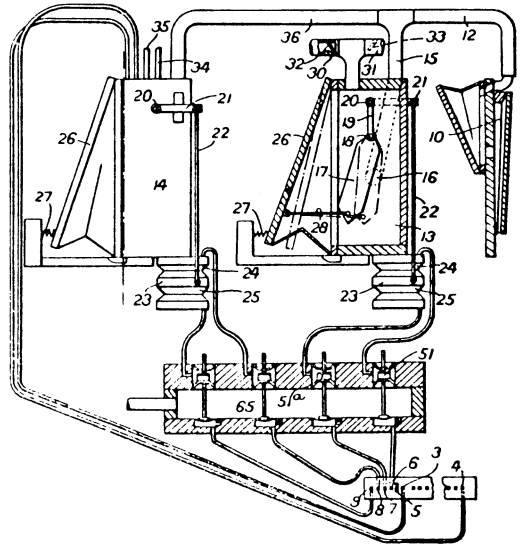

Figure 4

Expression, controlling; tune-sheets; blowing and exhausting air – Two valves, which are controlled by the tune-sheet, control a double bellows arrangement for oscillating the pivot of the governor-valve to vary the suction over the whole range of notes. A frictional device is provided to hold the governor-valve in any set position, and the tune-sheet apertures controlling it vary in length so that various gradations of expression are obtainable. A similar device



may be used for accenting individual notes, two valves for controlling a device which oscillates the pivot of a governor-valve, and two other valves for opening or closing connexions to the treble and bass sections of the action wind-chest, being provided. The bellows 10 exhaust the chests 13, 24 through the pipes 12, 15, and 36. The chest 13 is connected by pipes 30, 31 having non-return valves 32, 33 to the bass and treble sections of the instrument. The port 16, connecting the chest 13 to exhaust, is controlled by a valve 17 pivoted to an arm 19 mounted on a spindle 20. A rod 28 connects the valve 17 to the moving-board 26 of a governor bellows which is controlled by a spring 27. The spindle 20 may be oscillated by a double-bellows device 24, 25, the moving-board 23 of which is connected by a link 22 to an arm 21 mounted on the spindle 20. The bellows 24, 25 are controlled by valves 51, 51^a controlled by the tracker-ducts 6, 7. If the tune-sheet admits air to the duct 6, the valve 51 opens and connects the bellows 24 to the wind-chest 65. The collapse of the bellows 24 rotates the spindle 20 to move the pivot 18 of the valve 17 in one direction. The collapse of the bellows 25 by the opening of the duct 7 moves the pivot 18 in the other direction. The effective area of the port 16 varies according to the position of the valve-pivot 18, so that the suction in the chest 13 can thus be controlled to vary the loudness of the notes sounded over the whole range of the instrument. A blade-spring bears against the arm 21 and holds it in any position in which it is set, so that, by a succession of short tune-sheet apertures, the loudness of the notes sounded can be reduced or increased step by step. A similar device comprising a double-bellows

16 A Ramble on the Duo-Art Theme

controlled by the tracker-ducts 8, 9 is provided in connexion with the chest 14, which is connected by pipes 34, 35 to the treble and bass sections of the instrument. The pipes 34, 35 can be opened or closed by valves controlled by ducts 3, 4 in the tracker-bar, so that the tension in one section of the action windchest can be varied independently of the tension in the other to accentuate individual notes. A tracker-duct 5 controls the loud pedal. Specification 13,715/00 is referred to.

Figure 5 Duo-Art Dynamic Control System

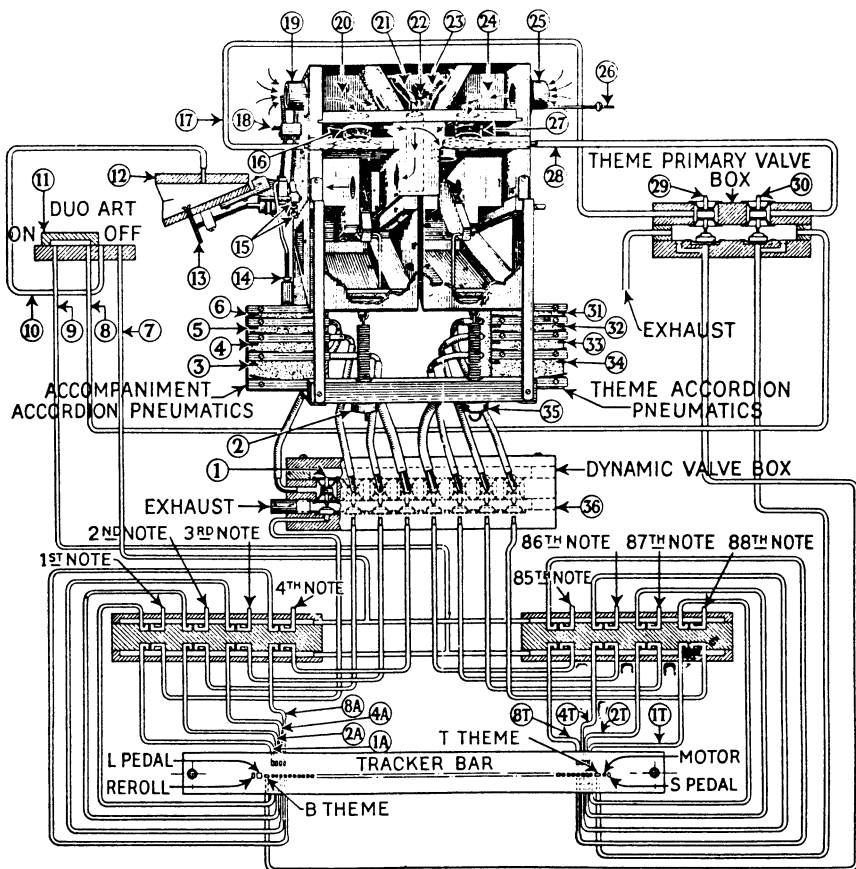
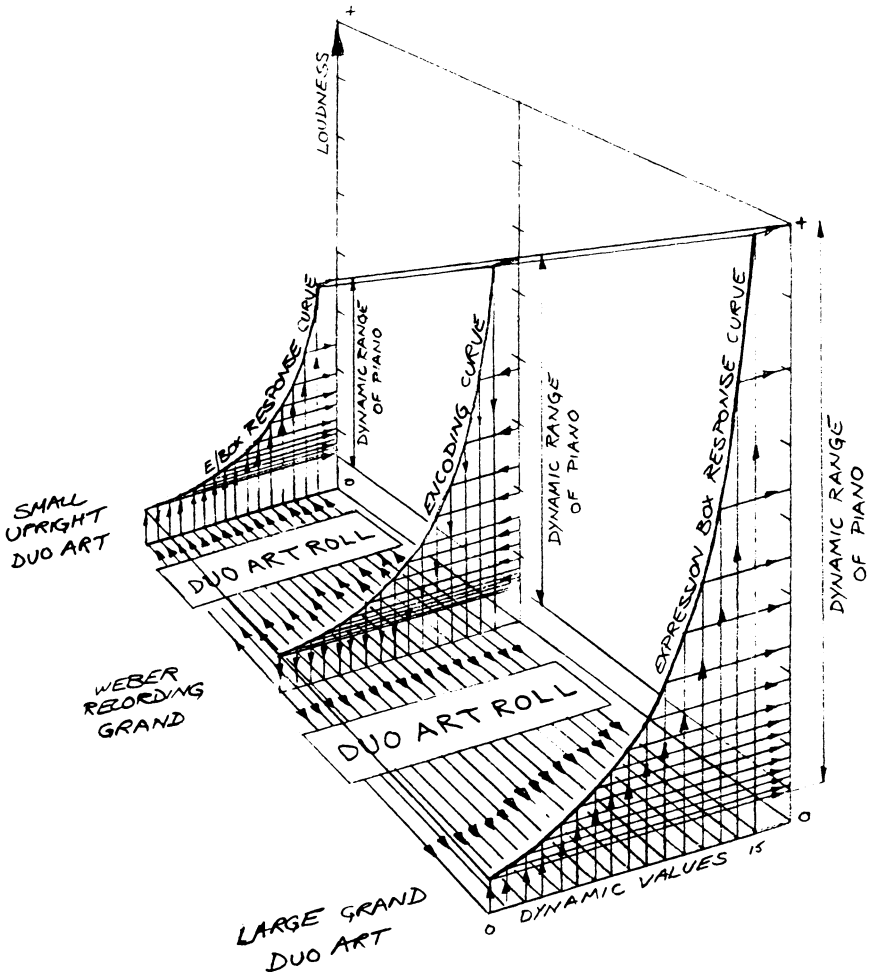

Figure 6 Duo-Art Response Curves



The Reproducing Piano*

John Farmer

INTRODUCTION

In the twenty-six years which have passed since these articles were written, our state of knowledge of the Ampico recording system has improved. Interviews with roll editors, some recording artists and, most importantly, Dr Clarence Hickman, who worked with Charles Stoddart, have been published by the Musical Box Society International. Some of the ground covered in these interviews was also dealt with in unpublished interviews conducted by the author with Edgar Fairchild and Dr Hickman. In addition, we have the diaries of Dr Hickman for the period 1925 to 1928. It was thanks to the efforts of Larry Givens in the first instance and the subsequent investigative activities of Nelson Barden in the second, that most of this material has come to light. From all these sources the following facts have emerged.

1. Ampico did not develop a note dynamic recording system until 1926.
2. It follows that virtually all recordings prior to 1927 were subject to full editorial supervision and the insertion by the recording editor of the dynamics against the note traces on the recording master sheet.
3. The object of the spark chronograph was, as far as possible, to eliminate the musical editor from the recording process and, for that matter, the pianist as a supplementary editor.
4. However, editing remained a necessary part of finished roll production, because the recording system contained many imperfections which needed to be overridden and corrected by a person with trained musical judgement. Nevertheless, the time consumed in producing a finished master roll was greatly reduced.

One fact emerged from these interviews which has not, to date, received any comment. The author was told by Edgar Fairchild that many Welte rolls were reissued as Ampico rolls after re-editing, transposition, and recoding. This occurred with big name pianists in the period prior to 1924-

* The two articles which follow are Reprinted from *Recorded Sound*, 25 January 1967, and 26 April 1967, by permission of the British National Sound Archive and the author.

and probably includes the first Jos. Lhévinne rolls and the Rubinstein rolls. Whereas Hupfeld transfers are designated on the label, no such attribution occurs in the case of the Welte re-issues. This practice may have ceased when Ampico acquired confidence in the superiority of its own system and, at the same time, a sufficiently large roll repertoire for its catalogue. Fairchild had a poor opinion of these transfers.

The author has been unable to distinguish any difference in recordings between dynamically edited rolls pre-1927 for the best artists and their spark chronograph recordings of later years. Of course, the best artists would only work with the best editors.

Many artists were exclusive to the Ampico system, e.g. M. Rosenthal, Levitski, Moiseiwitch, Rachmaninov, and so Welte anxieties do not arise in their case. Ampico rolls for which Welte duplicates exist, must fall under some suspicion, especially if issued by Ampico before 1925.

Our knowledge of the Duo-Art and Welte systems has not advanced much in the last twenty-five years. Both systems were always capable of excellent results given carefully edited and manufactured rolls. The American Licensee Welte rolls were carefully edited and this shows in their quality whether they were re-issues of European recordings or entirely of USA origin. Likewise, with the Duo-Art, whose English rolls were generally more uneven in quality than their US counterparts. Those wishing to learn of the fate of the UK Aeolian recording piano and their dynamic recording systems in use in England, should refer to G. C. Stonehill, who is the principal authority on this system. K. K. Caswell of Austin, Texas, enjoys this position for the Welte-Mignon.

Finally, it should be said that when the recording piano roll was rediscovered in the mid-1960s, the importance of the dynamics and the methods used to record them was much exaggerated by all of us interested in the faithfulness of these recordings. It has become obvious that a skilful editor present with the artist when he played, was just as capable of capturing the dynamic range of the performance as a sound recorder, or a spark chronograph. The essential element was the accurate placement of the notes, their duration and the sustaining pedal movements on the finished roll, for which the manufacturer relied on a sensitive recording piano and an accurate transfer process from edited master to the final perforated music sheet. There was a smoke screen around this process and Edgar Fairchild said that Ampico pianists were given the impression that a complete recording process existed before the spark chronograph was developed. The editor made dynamic notes on the music score during the performance and sometimes asked the pianist to repeat the pieces because

the recording had not come out properly. In reality this meant that the editor needed to rehear a passage.

PART ONE

The recent Argo LP discs DA 41, 42 and 43, taken from the Ampico music rolls, have aroused considerable interest amongst critics and musicologists. These records appear in a period of renewed interest in reproducing piano rolls following a series of BBC broadcast talks with illustrations on the topic of reproducing pianos.

Reaction to the Argo discs has been almost uniformly enthusiastic, ranging from reviews in the *Gramophone*, the *New York Times*, *The Times*, and other leading newspapers to broadcast discussions; almost all the critics seem to have been convinced of the fidelity of the recordings to the original performances of fifty or more years ago. This raises the question why such a remarkable source of recorded music should have been almost totally ignored for so long by all but a few private collectors, for there seems to be no doubt following the success of the Argo records and the publicity and interest in this topic generated by the BBC's apparent conversion to faith in the authenticity of reproducing piano rolls to which witness the frequent broadcasts made from the BBC's large stock of Ampico recordings that further records will be released by the major record companies. The pianists represented will include almost every pianist and composer for the piano who flourished in the period from 1905 to 1925. What purports to be the authentic playing of Debussy, Ravel, Granados, Pachmann, Carreño, d'Albert, Sauer, Rosenthal, Busoni and many others too numerous to mention will become available on modern records taken from the enormous quantity of recorded material contained in the perforated music rolls of the three major and competing companies in the field of the reproducing piano, namely Welte-Mignon, Duo-Art and Ampico.

The attraction of this source of material as against reissues of acoustic or early electric 78 discs lies in the quality of sound obtainable since by recording a reproducing piano playing from a fifty-year old roll all the superficial disadvantages of the early gramophone records are avoided. From commercial considerations this factor is important although the excellence of the modern studio recording technique is quite irrelevant in determining whether or not these rolls represent the pianists as they really played, however pleasing the resultant sound may be to the casual listener.

The purpose of this article is to consider in the light of the rather scanty

evidence available today just how far piano rolls can be trusted as faithful sources of information on the style, touch and skill of a past generation of pianists.

To begin with it should be established that all musicologists concerned with the art of piano playing have been aware of the existence of reproducing piano rolls but from the time when these rolls began to acquire historical interest it was no longer possible to hear them in satisfactory conditions since the manufacturers had in all cases gone out of business and the reproducing pianos that survived simply did not play well enough to enable a listener to determine whether poor results were due to defects in the rolls or to the malfunctioning of the reproducing mechanism in the pianos. The recent revival of interest is entirely due to a few enthusiasts in England and America who have rebuilt reproducing pianos to their original specifications so that one factor causing uncertainty has been eliminated.

The piano rolls which have recently aroused so much interest in broadcasts by the BBC and on the Argo discs were all played on a Grotrian-Steinweg model 185 6ft 2in. grand fitted with the model A Ampico action belonging to the author of this article.¹ These rolls were made by the American Piano Company or Ampico Inc. who began operations around 1912 in New Jersey, but who did not assume a commanding position in the piano trade until around 1920. Nor with a few exceptions did they obtain the services of any distinguished pianists until after that date. Thereafter the company flourished until the Wall Street crash put an end to the manufacture of expensive luxuries. This was a class into which reproducing pianos certainly fell. Their ownership tended to be restricted to the very wealthy to whom they were a novelty which like all novelties suffered from changes in fashion regardless of any particular merit possessed by the object in question.

Amongst the important musical figures who recorded for Ampico were Moriz Rosenthal, Joseph Lhévinne, Rachmaninov, Godowsky, Moisévitch, Artur Rubinstein, Levitzki, Schnabel, Dohnányi, Elly Ney, Fritz Kreisler (as a pianist), Robert Schmitz, George Copeland, Aaron Copland, and Yolande Méro. There were a host of others, many resident American pianists, whose fame did not reach Europe, some of whom were nevertheless fine artists.

In considering the importance of these piano roll recordings one point should be established at the outset. Piano rolls for reproducing pianos are not interchangeable between pianos made for the Duo-Art, Ampico and Welte systems. Therefore what is true for one type of roll must be

22 *The Reproducing Piano*

established afresh for the other makes. All these companies used similar recording systems, but the mechanism in their reproducing pianos which must re-enact the exact finger pressures and pedalling of the pianist in playing back the music roll differ completely from one another in manner of operation. Therefore it is most relevant to the purposes of this article to consider not only whether it was possible to make a fully accurate recording of a pianist's playing in a form which could be transcribed into perforations in a sheet of paper but whether the mechanism in the three different makes of piano is capable of correctly projecting this information into the ear of a listener in a manner indistinguishable from the original performance.

Before passing to a detailed description of the mechanism of the Welte, Duo-Art and Ampico reproducing pianos and as far as possible the recording techniques used to produce the original rolls it is useful to consider what evidence can be deduced from the available gramophone records of reproducing piano rolls. Although quite a number of transfers from rolls to disc have been made only three such groups of records have been made to date which provide sufficient data for this approach. The extensive Telefunken series of LPs was the first large-scale attempt to transfer this material and in this case all the recordings were taken from a Welte-Mignon model O Steinway grand, which was the property of the late Edwin Welte, co-inventor of the Welte-Mignon system with a certain Karl Bokisch who was a member of the Welte firm.

Preceding the Argo Ampico discs by about a year is an important issue of Welte recordings distributed by the Book of the Month Club classic Record Library division under the label 'Legendary Masters of the Piano'. Both the Welte series include recordings by composers such as Mahler, Debussy, Ravel, Saint-Saëns, Grieg and Scriabin as well as such masters of the piano as Josef Hofmann, Pachmann, Busoni, d'Albert, and many others. The Book of the Month venture provides more reliable evidence of the Welte system at its best because of the circumstances leading up to the final recordings. The Telefunken records suffer greatly by comparison as nothing like the same trouble in the preparation of the reproducing piano was possible in their case. Unfortunately Edwin Welte, who was an old man, died at the commencement of the recording sessions and no-one was available to adjust the piano which would in any case have needed substantial rebuilding if it were to have given of its best. The Book of the Month records were made using a Welte Vorsetzer machine playing on the keys of a modern Steinway concert grand. The Vorsetzer is a chest containing the reproducing mechanism which is pushed up to the

keyboard of an ordinary piano which it plays through the agency of a set of wooden levers padded with felt which press down the keys. In most cases the Welte system is built into a specially prepared piano but with the Vorsetzer there is the advantage that any piano can be selected for the performance. The piano pedals are also operated by levers to complete the effect. The Vorsetzer used was the property of the brilliant Texan collector Kenneth Caswell who is now the business manager of the San Antonio Symphony Orchestra. As well as possessing a high degree of musicianship Caswell is fully versed in the science of player piano technology and had completely rebuilt the Vorsetzer to conform with original performance specifications of the Welte-Mignon.

The records which resulted from this enterprise have been the cause of endless discussion and argument in the USA although they are not generally known in Europe yet.

The immediate impression gained from the records is that the performances are most enjoyable but are characterised in complicated passages by obscure articulation and a rather lumpy and irregular touch. Elsewhere much of the playing contains beautiful effects. Throughout the pianists' hands never seem to be quite together. In a long article in the *Saturday Review* Harold Schonberg dismissed these recordings as being of virtually no value and cited in corroboration the opinion of Artur Schnabel, to whom he had played the records. Schonberg based his criticism on some admittedly poor performances in pieces representing Busoni where the pedalling seemed impossible to attribute to such a great musical figure and on Schnabel's impressions of the quality of the playing in certain pieces, which he deemed to be highly uncharacteristic of the pianists allegedly responsible. It does not seem possible to write Welte off so easily. To begin with, as in all new inventions Welte rolls suffered from defects in their early days which were rectified as the company gained experience in the new field. A few faulty recordings need not invalidate the whole system. Secondly while Schnabel's views must be treated with respect another great figure, Rudolph Ganz, in a radio interview on a West Coast network took the opposite point of view in maintaining that Welte and Duo-Art rolls, of which he made a great many, were substantially accurate and trustworthy.²

None of the critics of the Welte recordings seems to have checked his conclusions by comparing the roll performances with early acoustic discs made by the same pianists. Such a comparison between Pachmann's roll recording of the D flat Waltz and his acoustic discs show identical phrasing and rhythmic characteristics although the magical touch is absent

in the Welte rolls. The playing is nevertheless less clearly recognisable as Pachmann's. Unfortunately the tone produced by all the pianists represented shows little variation and in this respect it is clear that Welte must be found wanting. So far therefore the case for or against Welte remains unproven although as will appear later, some of the failings of the Welte recordings can be attributed to the mechanism within the reproducing piano which leaves open the question of the accuracy of the original recording technique.

The Argo discs DA 41 and 42 are of Ampico rolls recorded by Joseph Lhévinne, Moriz Rosenthal and Rachmaninov. Of these pianists the most familiar to modern ears is Rachmaninov whose 78 rpm gramophone records have been reissued on various LPs under the Camden label. Few people nowadays are acquainted with the playing of Moriz Rosenthal in his prime and unfortunately the recent reissue by RCA is not representative of his best playing. A Camden reissue of Joseph Lhévinne's playing used to be available in the USA and from this two direct comparisons can be made with the Argo Ampico recordings. Most of the Rachmaninov Ampico rolls represented are available for direct comparison but with Rosenthal only the Chopin-Liszt *My Joys* can be treated in this way.

In the opinion of the author the distinctive tone quality of these three artists is quite clearly reflected in their Ampico roll recordings although the individual differences of sound texture are more attenuated by the medium of roll recording than by either acoustic or early electric gramophone records. Taking Rachmaninov, who can with experience be recognised from a few bars of his playing taken in isolation from the rest of a performance, the distinguishing timbre of his touch comes through almost as strongly on the rolls as on the 78 rpm discs. In rhythm, dynamics (meaning the degree of force applied to the keys), pedalling, phrasing, and tempi it is not possible to pin-point any differences between the rolls and the discs although it is of course the interrelation between the factors mentioned which produce a pianist's distinctive tone quality. But taken in isolation these components of the performances seem to match within close limits of tolerance, bearing in mind that the rolls and 78 records were recorded on different occasions sometimes years apart.

The overall effect of Lhévinne's playing with its effortless elegance and uncomplicated simplicity of interpretation is more distinctive and perhaps more important than the cool, crisp touch which creates his tonal characteristics. While this makes Lhévinne's playing less immediately recognisable than Rachmaninov's, a comparison between the Schulz-Evler

Blue Danube arrangement and the Chopin Etude in E flat, Op 10, No.11 on Camden Cal 265 – a record incidentally which the makers failed to provide with a sleeve note – and the Ampico versions show in the case of the Schulz-Evler a virtually indistinguishable performance and in the Etude a better overall impression in the Ampico version which avoids some slight harshness felt in the opening passages of the gramophone recording. With Rosenthal's playing of *My Joys* it was interesting to discover that although the tempo in this piece is rather free the two versions are, within a few seconds, of the same duration; this confirms the accuracy of Ampico roll drive mechanism in this instance. No other direct comparisons were available to the author for Rosenthal but in the Bortkiewicz Etude in D flat and in the *Carnaval de Vienne* there is much which is reminiscent of the Rosenthal of the Chopin E minor piano concerto in the unforgettable Odeon recording.

Another Triumph

for

The AMPICO

THE SUPREME REPRODUCING PIANO

On February 18th, 1927,

MOISEWITSCH

the eminent pianist, in his Piano Recital at Wigmore Hall, played in comparison with his own AMPICO RECORDINGS. The two performances—his own and that of The AMPICO—were identical.

The audience was spellbound by this marvellous and perfect reproduction, and continually applauded both the ARTIST and The AMPICO.

Nearly every Great Artist of modern times may be heard on The Ampico.

The Ampico Catalogue of Recordings embraces every type of music:

Classical, Semi-Classical, Transcriptions, Marches, Standard Melodies, Waltzes, and the latest Dance Music.

The Ampico is obtainable for home entertainment and enjoyment in Upright and Grand Models of many of the World's finest makes of Pianos.

We cordially invite you to call and hear The Ampico or write for Brochure of Great Artists.



"Not until I heard The Ampico did I feel inclined to make recordings—it makes me happy to be associated with your marvellous invention."

Bruno M. M. M.

In the outcome it can be stated that in the first two Argo discs Lhévinne, Rachmaninov and Rosenthal seem to be faithfully reproduced to the point where their different tone qualities can be distinguished, which certainly cannot be said for the Welte recordings so far released on disc.

The third Argo disc contains the playing of eleven pianists of varying importance. It is here that certain similarities of touch, of balance between right and left hand, and of evenness become noticeable between the artists in this group. Where with the Welte recordings one was prepared to blame the system for a recurrent roughness of tone and unevenness of touch the common features of these recordings are all desirable attributes of fine piano playing and many listeners have felt quite naturally that the original pianists should take credit for them. Unfortunately this similarity between so many different personalities is more likely to arise from the common medium of the Ampico roll than from any unity of playing technique amongst the pianists.

In conclusion a tentative deduction would appear to be that Ampico rolls are more reliable when they represent the truly great pianists by whom the solution of problems of technique can be taken for granted. In their case subsequent editing of the roll to correct deficiencies in technique would have been unnecessary and in consequence if one accepts in principle that the recording process was accurate there was less risk of points of interpretation being sacrificed for the sake of a polished sound, which may have been beyond the capabilities of the pianist even if he had something interesting and illuminating to say about the music.

In the next article the author will deal with the methods used to record the pianists by the roll companies and the different mechanisms in the reproducing pianos which re-enact the artists' playing.

PART TWO

Although Dr Ralph Hickman has recently explained the details of the spark chronograph method of hammer velocity measurement which was used by Ampico in the making of their piano roll recordings, less is known of the techniques employed by the Aeolian company and Welte & Son of Freiburg.

Dealing first with the makers of the Welte-Mignon rolls, the details of the recording process are shrouded in mystery and likely to remain so. The Welte company always insisted that their recording system was fully automatic, and certainly one eminent pianist who recorded for them, Rudolph Ganz, has described how, unlike Ampico and Duo-Art, Welte did

not ask for the services of the pianist in the later stages of preparation of the master roll. According to Ganz, Welte considered their methods to be complete and the first impression obtained from the recording piano required no further editing or improvement.

The Aeolian company would appear to have used several methods to record their artists. In common with the manufacturers of all 'hand played' rolls, whether reproducing or straight non-expression piano rolls, the Aeolian company used a recording piano with electrical contacts which measured the movement of the keys, dampers, and pedals. By a series of relays these movements were traced on a moving sheet of paper. In this way an entirely accurate recording of the beginning, duration and end of key and pedal movements was obtained. However, without some simultaneous means of registering the degree of force with which each note had been struck an authentic reproducing roll could not be constructed which would accord with our modern views of what constitutes a complete recording. In fact, it seems highly probable that, at some time in the history of the Aeolian company, the practice arose of having the dynamics of a performance inserted into the recording at a later date by editors – of varying degrees of skill. Reproducing rolls made in this way can be compared with an artist's portrait. Sometimes the perceptive portrait reveals more of the sitter's personality than any photograph. Such rolls are not necessarily inferior to those made by entirely automatic processes of recording but their quality is dependent on the skill of the editing staff involved in the final preparation. It is known that the Aeolian company made gramophone recordings of the pianist's performance which could be used by the editors to check their recollections of the dynamic range of touch employed throughout the piece. Direct measurement of the individual hammer velocity in the recording piano was later introduced – the method successfully employed by the Ampico company.

This measurement of hammer velocity was not a particularly difficult problem and it seems safe to assume that all the makers of reproducing piano rolls were aware of possible solutions, whether or not they actually employed them.

Ampico, who were more forthcoming about their system than the other companies, used the spark chronograph, which fired one spark through a moving sheet of paper as the piano hammer approached the string, and a second spark, in the final instant of travel, before it struck the string. The distance apart of the two minute spark holes gave the speed of the hammer, and hence the resulting loudness, of the note being struck.

A similar, if less refined, system was certainly available to the Aeolian company. It would seem however that they preferred in practice to insert note dynamics in the finished master roll with the aid and advice of the pianist. Moisévitch, in an interview in 1963 about his own recordings for the rival Ampico company, said that he considered that the small revisions that he was able to make when the first recorded impression was played back to him a few days later enabled him to project his artistic intentions 'absolutely'.

While former employees can still testify to the methods of the Aeolian and Ampico companies, theories about the Welte process are as yet unsupported by really detailed evidence. In the accompanying booklet to the Classics Record Library issue of Welte recordings, which were discussed in the previous issue, there is a vague description of the Welte process. According to the writer, John Conly, a contributing editor of *High Fidelity Magazine*, the recording piano had a trough of mercury beneath the keyboard. Each key had a light carbon prong suspended from its lower side which dipped into the mercury when a note was played. This was claimed to register the exact force and duration of each note. On its own this system could hardly have supplied more information than the duration of the note and was only a variation of the method used to take down the notes for a hand played roll as described above in which the dynamics of each note were unknown.

However, Mr Richard Simonton, who befriended Edwin Welte when the inventor was in the last years of his life, told me that the carbon prongs were in fact suspended from the key by a fine coil spring and consequently the depth of penetration of the carbon rod in the mercury would have varied with the force with which the key was depressed. From this it follows that the resistance to the flow of current would vary slightly with this depth of penetration and if this could be traced against each note a fairly good guide to the pianist's dynamics would be obtained. My own feelings are that this method was the one used but that the resulting readings would have only been approximations to the true tone volumes employed by the pianist. One reason is because the movement of a key may be irregular and the velocity imparted to this carbon prong would not necessarily have corresponded to the velocity of the hammer at the moment when it made contact with the piano string. Also it is unlikely that electrical measurement would have been accurate with the limited equipment available before 1914. Undoubtedly a system which directly measures hammer velocity is preferable but as will appear later it is doubtful whether the faults of the Welte-Mignon rolls can be ascribed solely to imperfections in recording.³

If the reader will now refer to the diagram of the expression control mechanism in the Welte playback piano some of the characteristics of the roll performances will be explained.

In the Welte piano two identical mechanisms control the force with which notes are played. These two mechanisms correspond roughly to the areas of the keyboard covered by the pianist's right and left hands. Thus all notes from E above middle C downwards are controlled by the bass unit and those above by the treble. The system becomes rather strained when both hands are playing together in either the treble or the bass sections of the keyboard since in this case one expression unit has to cope with the different dynamic requirements of the two hands. However, even in the ideal and most common situations when both hands are playing in their usual positions, problems of satisfactory play-back arise.

As will be seen from the diagram, the loudness of playing is controlled by the movement of a tapered plug which obstructs the airway leading to the vacuum pump. This runs at a constant speed delivering a steady force of between 35 and 40 inches of water suction. The movement of the plug decides whether the level of vacuum in the chamber supplying the bass or treble section of the note pneumatic array is between the 5 to 7 inches

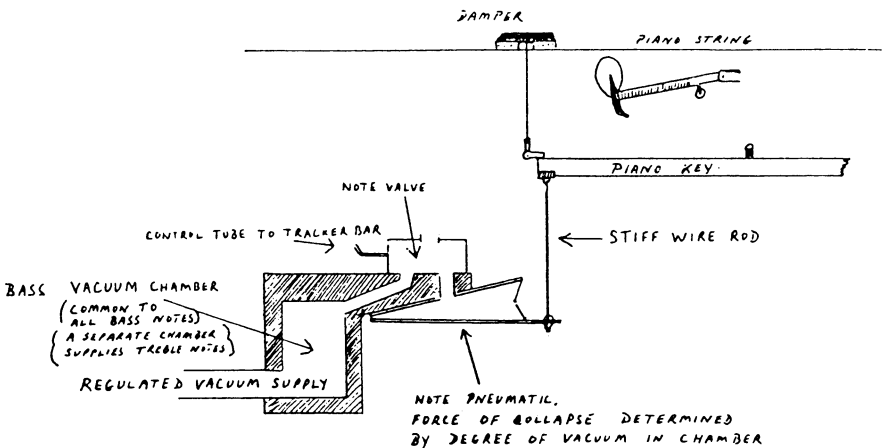

BASIC PNEUMATIC ACTION FOR PLAYING KEYS OF ALL TYPES OF REPRODUCING PIANO WORKING ON THE 'EXHAUST AIR' PRINCIPLE

30 *The Reproducing Piano*

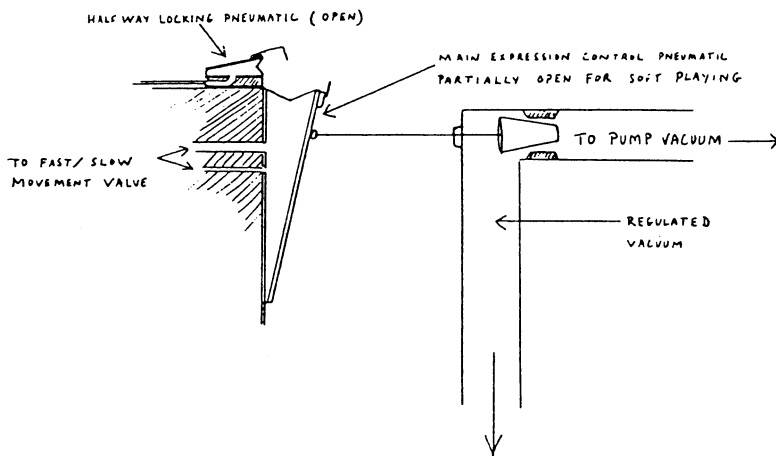

TO BASS VACUUM CHAMBER FOR BASS NOTES
ON PIANO KEYBOARD
BASS VACUUM REGULATING DEVICE (DUPLICATED FOR TREBLE)
FOR THE WELTE-MIGNON SYSTEM 1904 - 1930

required for soft playing up to the maximum of 35 to 40 inches for fortissimo passages. Obviously the speed and precision with which this vacuum level can be varied is most crucial to the effect of the performance.

The plug is moved in and out by a thin wire rod linked to a large pneumatic which can be collapsed or opened at two fixed and different rates. By switching on or off the larger valve supplying this pneumatic, a rapid movement in either direction is obtained. In this way accented notes or sudden increases in volume and loud crashing chords are achieved. The small valve causes a slower movement whereby full collapse is achieved in about 5 to 6 seconds. In terms of the level of playing this would represent a crescendo from pianissimo to fortissimo. Both valves are applied on and off continuously in order to try to follow the moods of the performance as directed by the instructions on the perforated roll in the form of single holes signalling 'off' or 'on' at the appropriate moments. The expression pneumatic is therefore only at rest in the fortissimo position, being collapsed as far as it will go, or again when fully open at pianissimo. In any intermediate position it will either close or expand slowly depending on whether the slow movement valve is on or off.

In a piece of music where the level of playing is neither fortissimo nor

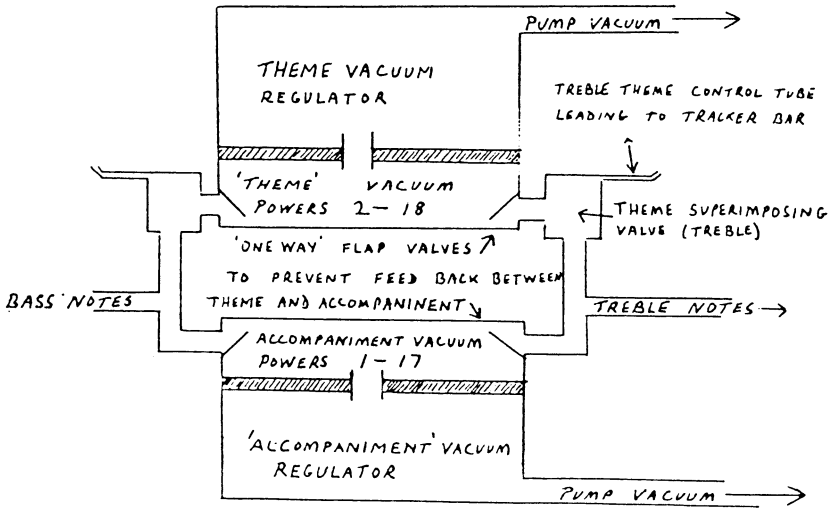

DUO-ART BLOCK DIAGRAM. THEME ACCOMPANIMENT SYSTEM

pianissimo a difficulty arises. Since the speed of movement of the pneumatic is never absolutely constant either from one piano to another or from one day to another due to changing atmospheric conditions it is inevitable that any slight variation in the rate of collapse or expansion from the original factory standard will introduce an increasing error in the position of the pneumatic and consequently in the level of volume of sound produced by the player mechanism. To correct this fault the Welte engineers fitted a small recentring pneumatic which when closed interposed an obstruction to the movement of the main pneumatic. When this small pneumatic was closed it prevented the main pneumatic from closing beyond the half-way point or, if the pneumatic was already fully collapsed for fortissimo playing, in opening beyond the half-way position. This provided a point of reference from which instructions to move in either direction could be commenced again. However, this recentring could only be achieved at convenient moments in the music and was in any case only a means of preventing the error from becoming excessive.

All this explains the rather rough effect of the Welte playing in certain passages and also the persistent lack of unison between the hands of every pianist represented. We know from gramophone records that such artists as Josef Hofmann could never be accused of this fault in real life. The

32 The Reproducing Piano

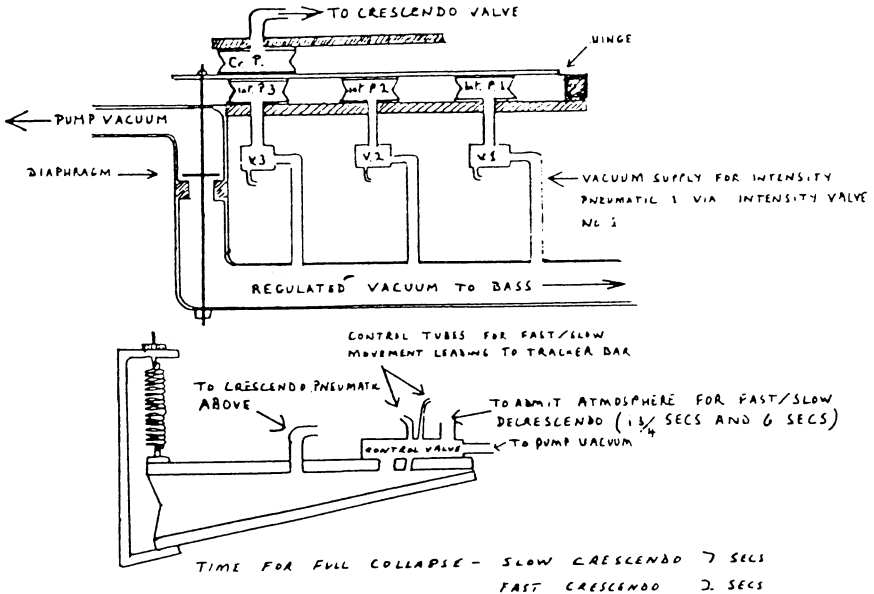

BASS VACUUM REGULATING DEVICE (DUPLICATED FOR TREBLE) FOR MODEL A AMPICO REPRODUCING PIANO MANUFACTURED 1911-1930

explanation lies in the fact that since the bass and treble units never deliver exactly the right vacuum level to their respective note pneumatics, the hammers for the bass and treble notes will arrive at the strings slightly later or earlier than intended because they are moved at the wrong speed. Since there is a separate and independent error in both sections chords which should sound in unison, and which are formed by notes in bass and treble, will be slightly broken. This characteristic is a continuing source of irritation in Welte performances.

Whereas the nature of the performance of the Welte seems to be closely linked with the expression system in the Welte playback piano the results obtained from both Duo-Art and Ampico rolls would seem to depend almost entirely on the manufacturing processes in the production of the rolls. The control systems in the Ampico and Duo-Art are capable of precise movements within their range of expression and also their speed of change is considerably more rapid than the rather cumbersome Welte unit.

The Duo-Art diagram shows the general outline of the system without going into any details of the very complex valve and pneumatic arrangement which governs its operation.

It will be seen that in designing the Duo-Art the engineers of that company decided that the notes of piano music could be best analysed as being divided into theme and accompaniment rather than into right and left hand. Thus the accompaniment control box supplies the whole keyboard range with sixteen increasing steps of vacuum. Any one of these sixteen steps can be selected rapidly for the appropriate accompaniment notes. The theme control unit overrides the accompaniment unit and supplies either the bass or treble sections of the keyboard depending on the requirements of the music. One of the most remarkable features of the reproducing piano is the speed with which a change of vacuum level can be communicated around the entire system. In all the three systems described in this article the limiting factor is the speed with which the mechanical obstructions, which throttle down the vacuum supplied from the pump, can be moved. The pulses of air which are created by a hole in the perforated music roll exposing for an instant its corresponding hole on the tracker bar pass down the thin signal tubes at approximately the speed of sound. These pulses operate the valves which either admit vacuum to the note pneumatics or to the pneumatics which control the expression units. The shorter the distance which the constituent mechanical parts of these units have to move in order to perform their functions the more rapid will be the response and the more complicated will be the instructions which can be carried out. Great speed of accentuation without interference with the level of volume of adjacent notes is a very important characteristic of the Duo-Art. Although the control units are fairly bulky and their moving parts are subject to considerable inertia – though being capable of at least as fast motion as the Welte parts – the Duo-Art has the great advantage that, while notes requiring only the accompaniment level of vacuum are playing, the theme unit can move into a position to supply a sudden impulse of vacuum to a particular accented note. But until the over-riding theme valve throws this different vacuum level into the bass or treble section where the theme note is situated the accompaniment unit controls the level of playing. Even the accompaniment unit on its own can control the expression in a fairly satisfactory fashion, since it can accomplish quite rapid changes in volume. By its nature however it cannot simultaneously supply bass and treble sections with different levels of vacuum and where this is necessary the theme unit will take over in either section of the keyboard. Whether the theme unit maintains continuous control of one or other section of the keyboard depends on the nature of the music. When – as for example in a Chopin nocturne – passages occur where all the notes in the treble section of the keyboard are melody notes

the theme unit would probably exercise continuous control. In the Chopin study, the *Aeolian Harp*, Op. 25 No.1, where the accompaniment arpeggios run simultaneously through the bass and treble, the theme unit would only inject to accent the melody notes. In such a passage the theme unit is switched off immediately after each melody note so that the succeeding accompaniment notes are controlled at the level determined by the accompaniment unit.

In this way the design of the Duo-Art makes it possible for the piano to perform in a manner which is beyond the capabilities of the Welte. On the other hand the division of notes between theme and accompaniment was decided during the preparation of the final master roll and if the pianist himself was not present this was a matter for the editing staff. The system described is obviously capable of playing the back a piece of music with the correct phrasing of the artist, providing an accurate recording was obtained in the first place. We know that like Ampico, the Aeolian company in its later days certainly used a recording process which was capable of providing the studios with sufficient data for the production of the reproducing music roll. On the other hand the editing staff had to decide exactly how, for each roll, they were to use the theme and accompaniment units to re-enact correctly the dynamics of the pianist's performance. At this stage individual tastes and preferences were bound to be involved and we know that the editing of the Duo-Art recordings was a most important stage in their manufacture. Percy Grainger personally carried out the mechanical operations involved in the correction and editing of his own rolls. Josef Hofmann also took an active interest in the production of his own master rolls. In fact both Grainger's and Hofmann's rolls are of a consistent standard which testifies to the enthusiasm which both these pianists expressed towards the player piano.

In evaluating Duo-Art rolls it is necessary to know their date of manufacture and whether they were recorded in the American or English divisions of the Aeolian Corporation because of the differing circumstances involved in their editing and recording. This can pose quite difficult problems for the musicologist and it is fortunate that the owner of the finest collection of Duo-Art rolls, Gerald Stonehill, has made a close study of this matter.

Both Duo-Art and Ampico reproducing systems appeared around 1911 and it is difficult to discover which was developed first. Welte had already been in production for seven years and had begun to export to the American market. The Aeolian Corporation, as a large manufacturer of player pianos and ordinary piano rolls, doubtless felt it necessary to offer

competition and we can assume that it was the example of the Welte invention which spurred the company to produce an effective rival product.

The first Duo-Art pianos performed a double function, as the name implied. Whereas the Welte could only be used as a fully automatic device to play back a Welte roll with the expression and dynamics contained in the perforations, the Duo-Art in contrast could play the special reproducing rolls recorded for it or, by throwing a switch, could be operated with foot pedals as a ordinary player piano; the operator was then able to insert his own tempo and expression by manipulating the various knobs and buttons, with which the Duo-Art was provided.

The manufacture of Duo-Art reproducing piano rolls was only a part of the activities of a large firm and, as explained, the pianos designed to play the reproducing rolls were not made exclusively for this purpose. This conflict of interests probably explains the uneven quality of the Duo-Art rolls of the early period from 1911 to around 1919.

The circumstances surrounding the development of the Ampico system were quite different. The inventor, Charles Stoddart, was not connected with the music industry and was already famous for a number of inventions in diverse fields which brought him a substantial income. One of the simplest, and the most profitable of these was the familiar mail chute found on the landings and staircases of many American hotels.

As related to the author by Mr Adam Carroll, who was associated with Ampico between 1923 and 1929, the tradition in the company ran as follows.

Charles Stoddart belonged to a fashionable golf club on the outskirts of New York frequented by most of the prominent businessmen and society figures of the day. On one occasion he entered into an argument with some of his fellow members on the factors involved in driving a golf ball the maximum possible distance. Stoddart's contention was that the weight and strength of the player wielding the club were immaterial to the distance which the ball travelled. He claimed that the only factor which governed how far the ball was struck was the speed with which the club head moved at the moment of impact. To prove his point he devised an array of fine wires which offered no resistance to a player's swing but which caused a series of electrical contacts to be made as the club head moved. These contacts were registered on a sheet of calibrated paper moving rapidly between two rollers, and the speed of the club head could be arrived at by a simple calculation. A series of test drives performed by a number of players proved beyond all doubt that as Stoddart had claimed the distance travelled by the ball was exactly proportional to the speed of the club head.

At this time nearly every bar and place of entertainment in the United States boasted a nickelodeon, which was a crude mechanical piano operated by the insertion of the appropriate coin. The racket which these devices emitted was agreeable when first encountered, but soon became trying to the nerves and patience of those within earshot. Stoddart's friends used to ask him why as a successful inventor he could not design some improvement in these machines which would enable them to play with sensitivity and a semblance of musicianship. Remembering his golf club machine Stoddart realised that the same principle could be applied to the measurement of the speed with which the hammers of a piano moved. Thus was born the idea of the Ampico recording system. To complete the picture he worked out a device for controlling the playback of a piano piece recorded in this way so that very precise measurements obtained from his invention would not be distorted by a player piano control system of a lower order of accuracy.

The diagram of the Ampico model A control unit shows that Stoddart adopted a method similar but far more precise than the Welte. Like the Welte the note pneumatics are supplied with variable vacuum from a bass and treble vacuum chamber. Two identical units control the level of vacuum in each chamber.

A flat diaphragm obstructs the main tube leading to the treble or bass vacuum chamber. Unlike the tapered plug in the Welte diagram this diaphragm has only to open $\frac{3}{16}$ th of an inch to admit full pump vacuum to the note pneumatics. Thus the problem of inertia presents far fewer difficulties. The diaphragm is moved by a thin wire rod attached to a light wooden lever rather like a thick school ruler. To the under-side of this lever are fixed three intensity pneumatics. When vacuum is admitted to these pneumatics they try to close, and the diaphragm moves downwards, constricting the gap through which air must pass for the pump to be able to lower the vacuum in the bass or treble. Acting in opposition to these intensity pneumatics is the crescendo pneumatic. This is attached to the other side of the lever and is under constant tension, being supplied with vacuum from the crescendo valve (which is shown in simplified form). For the softest playing the valves supplying the three intensity pneumatics (of which only one is shown in the diagram) admit vacuum, causing closure of the diaphragm. The crescendo valve is then adjusted so that a sufficiently strong vacuum is admitted to the crescendo pneumatic to force the diaphragm open a fraction. Because the valves supplying the intensity pneumatics derive their vacuum supply from the side of the diaphragm away from the pump the amount of strength exerted by the intensity

pneumatics depends on how far the diaphragm is open. This has some very important consequences on the degree of control which can be exercised over the bass and treble.

Where a very slight degree of emphasis is required in a pianissimo passage the valve supplying number 1 intensity pneumatic will be switched off by a perforation in the music roll. This allows atmosphere to be admitted to the number 1 pneumatic which therefore ceases to pull down on the lever to which the diaphragm is connected. The crescendo pneumatic, meeting with less resistance, forces the diaphragm open slightly until the level of vacuum increases. This increase in the level of vacuum is transmitted to intensities number 2 and 3 since their vacuum supplies come via valves fed from the regulated vacuum which the diaphragm controls. Thereupon the system falls into balance again with slightly higher vacuum throughout.

If vacuum be again applied to number 1 intensity and atmosphere be admitted to number 3 intensity a greater increase in vacuum will be achieved since number 3 intensity being furthest from the fulcrum point exerts the greatest subduing effect on the diaphragm.

It is important now to compare the effect of admitting atmosphere to number 1 intensity after number 3 intensity has been opened.

Whereas in the first instance number 1 intensity had caused a barely perceptible increase in overall loudness the effect is now more noticeable. This is because although nearest to the fulcrum and exerting least pressure number 1 intensity exercises an increasingly powerful suppressing influence when the other intensities are exposed to atmosphere. Therefore its impact when switched off is proportionately greater on the volume of playing.

If the valves controlling the intensity pneumatics were supplied from a source of constant vacuum the difference in effect on the volume of playing between powers 5 and 6 would be undetectable to the human ear. (Power 5 represents the level of vacuum achieved by admitting atmosphere to numbers 2 and 3. Power 6, which is the highest power of playing, is of course when intensities 1, 2 and 3 are all off.)

From this it might appear that the Ampico only uses seven levels of volume, since the various combinations of three intensities in the on or off position total no more than seven. In fact for much of any performance seven different levels of tone from pianissimo to fortissimo will produce an effect on the listener that is truly indistinguishable from the pianist's live performance. However by use of the crescendo valve the Ampico can produce an even crescendo and decrescendo effect which can be

superimposed on the seven steps of tone volume which are created by use of the intensity pneumatics.

If one refers again to the diagram of the model A Ampico it will be seen that the crescendo valve is linked by a tube with the crescendo pneumatic which pulls in the opposite direction to the intensity pneumatics. In the normal position the crescendo valve delivers just enough vacuum to enable this crescendo pneumatic to overcome the intensities sufficiently for the bare amount of vacuum to reach the note pneumatics for very soft playing. However, at a signal from the roll expression perforations the crescendo valve will begin to collapse against the spring which is trying to force it open. During this collapse which can take place in about 8 seconds for a slow crescendo or 2 seconds for a fast crescendo, the vacuum level in the crescendo pneumatic increases in strength so that it overcomes progressively and completely the intensity pneumatics. In practice, during the course of such a crescendo in a piece of music, certain notes require accenting above the general level and this is accomplished by using the intensities in conjunction with the crescendo.

Such a system provided the manufacturers of Ampico rolls with a completely effective way of re-enacting the dynamics which their recording machines had accurately measured. Nevertheless the company and the inventor Charles Stoddart himself were most insistent that a further requirement had to be adequately fulfilled before a recording could give a truly lifelike impression of the artist. According to Stoddart almost the most important characteristic of a performance was the pedalling and half pedalling of the pianist which created the tone colourings and atmosphere which distinguished one pianist from another. He claimed that by measuring with minute accuracy the movement and speed and depth of movement of the dampers it was possible to recreate the same tonal effects by extending the note perforations on the music roll, in order to preserve certain harmonies and disharmonies which had not been damped out by the pianist.

The application of this technique was certainly unique to the Ampico and was actually patented by the company to forestall imitation by their rivals. Nor was the colouring which these extended note perforations gave to the music a gloss on the original recording interpolated by the ingenious editing staff. Two pieces of evidence gainsay this. Firstly Ampico rolls are the only ones known to the author which convey the distinctive touch of a pianist in a manner which can be recognised. Secondly the Ampico company obtained a number of Hupfeld recordings which were rolls recorded in Germany for the reproducing pianos made by the Hupfeld

company under the name of the Dea or Triphonola. These Hupfeld rolls were issued under the Ampico label with a note to the effect that they had been adapted from the Hupfeld system.

While some of these adaptations are interesting historically none of them can be mistaken for a true Ampico recording. Yet if the secret of Ampico lay in the editing methods employed it would surely have been possible to doctor these Hupfeld adaptations up to the usual standard of the Ampico.

Hupfeld recorded as many pianists and composers as Welte and at approximately the same period. Unfortunately the author has not yet encountered a Hupfeld piano which works or is likely to work, but from a brief examination of several Triphonola rolls it would appear from the scarcity of expression perforations that this system has disappointingly little to offer compared with either of the other three.

Ampico model B has not been dealt with in the article because historically it is unimportant; it did not appear until 1929. Whether the model B Ampico arose because of the expense of manufacture of the original model, or whether it was created because the company were not satisfied with the effectiveness of the model A may never be known. That it should have come so late in the day was a tragedy since it virtually solved every problem in player piano technology by the application of a simple but revolutionary new principle. But that is another story.

Notes

1. Contrary to the accounts of this piano circulated by the BBC and later Argo the piano had not been 'fully rebuilt'. It played as well as it did after fitting replacement tubing and the patching of some leaks. However, much time was spent on adjusting the playing levels and piano action.
2. The author has access to a tape recording of this interview.
3. It seems more likely that a longer period of contact with the mercury resulted from a harder key-stroke – resulting in a longer trace mark on the moving recording roll which was matched with a trace showing the length of key depression for that note.

The Player Piano on Record - a discography

Denis Hall

PLAYER PIANOS AND PLAYER ORGANS

Although many more foot-operated player pianos were made than the more expensive reproducing pianos, by their very nature and their main function, that of a means of home entertainment, there has been less interest in making recordings to preserve the playing of pianolists, in spite of the fact that their playing has sometimes reached a high standard of musicianship. Some of them could well teach the traditional pianist a thing or two about interpretation. Even today, it does not seem to be appreciated that it takes a good deal of skill and a lot of hard work to produce even a competent pianolist; after almost a hundred years since the development of the pianola, it is likely that we have not yet heard a performer who has mastered the complete pianola technique and has the musical insight to use it, any more than we have heard or are ever likely to hear the perfect pianist. This is surely one of the great fascinations of the pianola – that it is the musical ability of the pianolist which controls the beauty, or otherwise, of the performance of the music roll.

A number of the discs listed here were already introduced in the article in *Pianola Journal* No. 2 (1989), so the same ground will not be covered again. The writer can report that he has now heard a second of the Easthope Martin 78 rpm discs which sound every bit as musical as the one noted previously. The instrument used on that series of records has been shown as 'Grand Organ', which is how it is described on the record labels. It is just possible that it was a pipe organ recorded very closely, but much more likely to be an Aeolian Orchestrelle, an elaborate reed organ. In either case, the instrument must have been played by means of a music roll.

Many of the great jazz pianists active in the first thirty years of this century made what are known as 'hand-played' rolls. These record the note durations and tempi of the playing, but not the dynamics. Given a sensitive interpretation by a pianolist who knows the style of the pianists, these rolls can give a very creditable portrait of the playing. One example has been included (London AL 3511). The pianolist is credited as being J. Lawrence Cook, the masterly music roll arranger who worked for QRS Music Rolls for many years; he plays rolls cut by James P. Johnson, and the result is a demonstration of just how good such a process can be. The

roll companies were always trying to boost sales, and they sometimes would issue rolls bearing such wordings as 'as played by ...'. There is considerable doubt as to the authenticity of these rolls. Some of the rolls attributed to Gershwin, and even more particularly those of Scott Joplin, are extremely dubious. There are many bad examples of jazz rolls on LP and CD which have just not seemed worth listing. The writer has even heard cases where the recorded quality has been degraded to make the disc sound like an old 78 rpm record!

The writer has broken with his usual practice this time and included an important semi-private recording of Stravinsky's 'Les Noces'. This recording of the second version of the work, which was not completed, was made in Switzerland in 1988. The instrumentation includes a pianola, harmonium, two Hungarian cymbaloms and percussion with the usual choir and four vocal soloists. The performers were the choir and orchestra of the Städtisches Gymnasium, Bern-Neufeld, under the baton of Adolf Burkhardt. The performance of this version has only been made possible by Rex Lawson cutting a music roll of the pianola part. The world première took place in Paris in 1981 and was conducted by Pierre Boulez; this is the first recording.

Of the recordings listed, those by Rex Lawson can be unreservedly recommended. The one published HMV of Reginald Reynolds is a real tour-de-force, particularly the Tchaikovsky side, and brilliantly demonstrates the control possible with a pianola piano in its prime and carefully set up and adjusted. The accompaniment records show Reynolds to have been a sensitive musician.

There is a revival of interest in foot-operated player pianos. Perhaps some of the better examples on record will inspire the owners of the instruments to keep practising and derive more and more pleasure from the vast library of music rolls available.

42 *The Player Piano on Record - a discography*

Record Label Carrier Catalogue Number	Artist	Composer	Title	Instrument	Date
HMV C270 Mono 78 C271	Easthope Martin	Wagner Mendelssohn	<i>Lohengrin</i> , Prelude Act 3 Wedding March	Grand Organ "	1913
C272	"	Guilmant Handel	Grand Chorus in E flat <i>Cuckoo & Nightingale</i>	"	1913
C273	"	Martin Batiste	Evensong Communion in G	"	1913
C298	"	Lefebure-Wely Handel	Offertoire in E flat Hallelujah Chorus	"	1913
C327	"	Sullivan Batiste	<i>The Lost Chord</i> Communion in E	"	1913
C461	"	Guilmant Lemmens	March Religieuse Op 15/2 Fanfare in D	"	
Aeolian Mono 78 MO466/7	J.H.Clapham	Lemmens Widor	Marche Triomphale Symphony in F minor	"	
MO468 (unissued)	Laurance Folkert/ Reginald Reynolds	Elgar	<i>Salut d'Amour</i>	Pianola Piano (Demonstration record)	1927
MO469 - 28001 - 3 MO470 (unissued) MO471 (unissued)	" " "	Phillips Clarke Martin	<i>Fisherman of England</i> <i>The Blind Ploughman</i> <i>Fairings</i>	Bartitone/ Pianola acc. " "	
MO471X - 28002 - 4	"	Woodford Finden "	Kashmiri Song (from Four Indian Love Lyrics)	" "	

MO472 (unissued)	Elsie Francis Fisher/ Reginald Reynolds	Bridge	<i>Love Went A Riding</i>	Contra/lo/ Pianola Acc.
MO473 (unissued)	"	Dvorak	Songs My Mother Taught Me	"
MO474 - 28002 - 4	"	C.Bohm	<i>Still As The Night</i>	"
MO475 - 28001 - 3	"	del Riego	<i>Sink Red Sun</i>	"
HMV Mono 78				
2B7279-1 (unissued)	Reginald Reynolds	Milde	<i>La Capricieuse</i>	Pianola Piano
2B7280-2 (unissued)	"	Delibes	<i>Pizzicato (Sylvia)</i>	"
2B7281-1 (unissued)	"	Grainger	<i>Shepherds Hey</i>	"
2B7282-1 (unissued)	"	Vogrich	<i>Staccato Caprice</i>	"
2B7282-1 (unissued)	"	Chopin	<i>Etude Op 10/12</i>	"
C2746 (2EA2013)	"	Liszt	<i>Feux Follets</i>	"
(2EA2014)	"	Tchaikovsky/ Rachmaninov	<i>La Belle au Bois Dormant - Valse Automne</i>	"
OEA2015-1 (unissued)	"	Chaminade		"
OEA2015-1 (unissued)	"	Rubinstein	<i>Valse Caprice</i>	"
OEA2016-1 (unissued)	"	Mendelssohn Scott	<i>Bees Wedding Danse Nègre</i>	"

Note: OEA2015-1 and OEA2016-1 were allocated matrix numbers. In a letter in the form of a contract issued by HMV to Reginald Reynolds, the titles of the four sides, Tchaikovsky, Chaminade, Rubinstein and Mendelssohn/Scott are listed although only the first two were issued on C2746. It seems reasonable to assume that the remaining two sides were made but destroyed.

London Mono LP AL 3511	J. Lawrence Cook	Johnson	<i>Charleston I've Got My Habits On Harlem Strut Vampin' Liza Jane</i>	Player Piano	1955(?)
------------------------------	------------------	---------	--	--------------	---------

44 *The Player Piano on Record - a discography*

J. Lawrence Cook	Johnson	<i>Har-lem Choc' late Babies on Parade</i> <i>Make Me A Pallet On the Floor</i> <i>Loveless Love</i> <i>It Takes Love To Cure the Heart's Disease</i>	Pianola	10/6/81
Erato Stereo LP STU71428	Stravinsky	Etude pour Pianola	Pianola	1982
Composers' Voice Donemus, Amsterdam Stereo LP 8404	Maarten Bon	<i>Boreal</i>	Pianola	1986
Fonoteca Stereo LP PAN PRC S20-34	Casella	Trois Pieces pour Pianola 1. Prelude 2. Valse 3. Ragtime Pacific 231	Pianola Piano (Electric)	"
Turicaphon Stereo LP 50-113	Honegger	<i>Les Noces</i> (1919 version) Tableaux 1 and 2	Pianola	4/5/88
Pickwick IMP Masters Stereo CD MCD 25	Stravinsky	<i>The Rite of Spring</i> (Version for pianola by Stravinsky)	Pianola	1989
Music Masters Classics Stereo CD 01612-67094-2	Antheil	<i>Ballet Mécanique</i>	Pianola	3/4/91
Rex Lawson Maurice Peress (Conductor) New Palais Royale Orchestra				

Rachmaninov's Russia and a Stravinsky Première

Robert Matthew-Walker

Of the many commemorations of the 50th anniversary of Rachmaninov's death, the most intriguing was given at the Purcell Room on 17 July by Denis Hall and Rex Lawson in association with the Pianola Institute. The programme was made up of Duo-Art piano rolls, the first half devoted to those by Rachmaninov himself and by several of his contemporaries, and the second of rolls which needed a pianolist to oversee the play-back.

With interesting informal anecdotes Denis Hall and Rex Lawson introduced each item in the first half. The rolls were variable in quality, not in the reproduction itself which was uniformly sound, as in the musical quality – variable standards of which obtained in concert-giving of a century or so ago. In this regard, the first item, Saint-Saëns's transcription of the Sinfonia from J. S. Bach's Cantata no. 29, set the scene for much of what was to follow: here was an item we never encounter today, a rare piece of music-making and memento of the unique Lev Pouishnoff. Such a description applied with greater force to one of the rare piano rolls by Alexander Siloti – Rachmaninov's first cousin and the second man to play Rachmaninov's C minor Concerto (with the composer conducting – Siloti conducted the première). This was Siloti's own edition of Liszt's *Benediction de Dieu dans la solitude* – the third of the *Harmonies Poétiques et Religieuses* – an intriguing piece, for Siloti, who made no commercial gramophone records, was a pupil of the master.

Then followed another exceptional item: Ossip Gabrilowitsch and Harold Bauer in the Waltz from Arensky's First Suite for two pianos, which must have been recorded as a duet. Three Prokofiev rolls showed this wonderful artist in his own music – the Gavotte and Rigaudon from his opus 12 and in Rachmaninov's G minor Prelude – this last a performance of quality, even if the tempo appeared a trifle rushed. Rachmaninov himself was heard in a new version for Duo-Art Pianola by Rex Lawson of the composer's Ampico roll of the C-sharp minor Prelude – a truly great reading, and a 1929 roll of an early Scriabin Etude played by Elena Yalkovsky was utterly compelling. The Horowitz account of Tchaikovsky's Doumka from opus 59 was rather a disappointment – there was undoubtedly something lacking on this occasion, although precisely what is difficult to pinpoint. Finally, a roll by Shura Cherkassky of Rachmaninov's Polka de W.R. brought this engrossing first half to a conclusion, but the evening's high-spot was still to come – nothing less than a Stravinsky world première!

This was the previously publicly unheard pianola version, made by Stravinsky in 1919, of *Les Noces*, on five rolls, kindly loaned for the performance by the Royal College of Music, given by both Denis Hall and Rex Lawson on two pianolas. To those who love this harshly glittering masterpiece, by turns endearing and deeply moving, here was a musical event of major importance – a compelling justification of the medium which fascinated Stravinsky for 15 years of his life, and which came as little short of a revelation, an entirely valid and convincing view of this great music. It should certainly be recorded, with Stravinsky's other pianola music; deeply grateful thanks are due to this enthusiastic and dedicated duo for making such a fascinating experience possible.

Recent Pianola Roll Issues – a review

Dan Wilson

A mark of the really superior hand-played roll is its capacity to convey something of the atmosphere of its original recording. Animatic rolls dated between 1909 and 1930 seem to do this. There's a sense of the pianist, easy in mood with a cigar, happy that his mistakes can all be rubbed out, and the technical staff, damp round the collar lest something will go wrong and an expensive booking be wasted. A knife switch is thrown, heavy motors turn in the basement. The pianist gets the nod and cruises out on to the keyboard ... we are in Arcady.

Exactly this sense, minus the heavy motors, is conveyed by Piano Medley No. 7, the last of seven issued by Malcolm Robinson of Southport under his Soroco label following his initial Charles Mitchell medleys three years ago. The pianist this time is Roger Quick, a supreme improviser in 'hotel piano' style, and on this roll he enters with a gentle cascade of chords as though not sure yet which key he will start in or which titles he will include in the medley. Having felt out the keys, off he sets into a reflective version of *Beautiful Dreamer*.

For the Friends of the Institute's pianola appearances in the Royal Victoria Place shopping centre in Tunbridge Wells, using a 65/88n push-up on a new Reid-Sohn grand, there is a specification for the music set down by the manager: it must be the sort of piano music the customers expect and like. All this really rules out in practice is rough playing and loud climaxes, and we have included everything from Chopin to blues. But 'hotel piano' fits the bill perfectly and for our first appearance there Malcolm kindly supplied all the Roger Quick titles. There are also two medley rolls based on shows, Novello's *Gay's The Word* and *Perchance To Dream*. The sense of the titles being adventitious is strengthened on finding that *A Nightingale Sang In Berkeley Square* appears on two rolls, in by no means the same form. Also Roger Quick enjoys a joke with himself, and those of us with an ear for it, by including the tune of one number in the accompaniment to the following one. No respect whatever is paid to *Chattanooga Choo-Choo* in Piano Medley No 5, which is played with glorious discordancy and stumbling foolery before vanishing in a multi-tonic phantasm.

All these rolls are recommended, including the show rolls which are more orthodox medleys in reproducing-roll style, well up to the old standards.

The modern jazz pianist Vincent Newton appears on three Soroco medleys: the first made two years ago was a success but on the second, he quite audibly runs suddenly out of ideas and begins to tinkle the keyboard unproductively. It is a novel experience to find this happening on a piano roll. I will buy his third one after I have heard it! All the recent Soroco rolls, incidentally, suffer from expansion with humidity resulting in the end notes missing, so if you live in an unheated house a good tip is to keep them in a cupboard against a warm wall. I actually bag them with silica gel sachets to get perfect tracking - it takes around a month to dry the roll out - but this is a purist's thing. Extreme dryness is not good for rolls, incidentally - the difference in condition between old cheap American rolls originally sold in Britain and those only recently imported is dramatic, the latter being perilously brittle. According to book restorers, this is because water helps paper fibre to remain matted, whereas dry fibres unravel and do not support each other when bent. Weakening of the fibre is not water-linked but due to retained acids, higher in cheap paper.

Nowadays American rolls incorporate wax which both reduces the acid action and helps to lubricate the roll as it plays. These rolls are likely to be playable in AD 2100 and beyond.

This is fortunate, because there is some good music coming out of America on rolls these days. The big producers like QRS and PlayRite, alas, persist in punching the maximum number of sheets at once and, it seems, sending the poorly-cut bottom copies to overseas customers - though whether they have the organisation to do this deliberately to deter returns, as some distributors darkly hint, seems questionable.

These criticisms do not apply to the rolls cut for various small labels by Richard Tonnesen of Custom Music Rolls in Texas, which include BluesTone, Front Porch and Hot Piano Classics.

The first two of these are labels of Rob DeLand in Palatine, Illinois. BluesTone are in effect, since they are copied so accurately, reissues of rare original ragtime and jazz rolls of between 1915 and 1930, many borrowed from large collectors such as Trebor Tichenor. It is not understating Rob DeLand's efforts to say that they rank along with some of those vital eighteenth-century copyists in ensuring by duplication that music from a fascinating and critical period of development will survive to far posterity. There have not been such rare rolls this easily available in England before. To invest in every title of the hundreds already produced is more than this collector can afford, but the temptation to fill the garden with shelved Portakabins is great. In amongst better-known jazz pioneers represented here is Jimmy Blythe, mostly known on records as a backing

pianist, who as staff pianist for the Capitol company cut dozens of hot numbers for multiple-tune nickelodeon rolls. These are now separated out on to ordinary rolls and many are small classics, lacking any sense of being 'period' music.

Jazz rolls respond well to the expressionless playing of the pianola beginner, but much extra pleasure can be had out of them by discovering the gentle accents that would have given the original recording such bite. On the Front Porch label the efforts of present-day jazz players are reproduced from MIDI recordings and DeLand has commented in a letter published in the Player-Piano Group Bulletin that he has had to edit them to suit 'even-power' playing. What this mostly means in practice is that the softer accompaniment notes have been shortened and in some instances delayed to mimic the later strike of gentle touch. This unfortunately makes it more difficult to regain in playing some of the original light and shade; but, this said, these are mostly rolls worth having and a few are even outstanding - notably *Frankie & Johnnie Boogie* .

Hot Piano Classics, put out by Mike Schwimmer of Lake Bluff, Illinois, along with his own 'Mike and Annie' recuts from original rolls (identical perforation and quality to BluesTone) is effectively the British Jazzmaster operation continued transatlantically, though around 1989 there was an overlap of about a year. The jazz pianist John Farrell makes manually-cut master rolls in England which are then copied and marketed in America. This makes better commercial sense, but there has also been a musical difference: Farrell wanted to diversify away from the early piano jazz styles preferred by Jazzmaster. The result has been a great library of piano jazz transcribed from sheet music and by ear from records, some of it perhaps more successfully than others. The 1930s and 40s pieces, representing typically Teddy Wilson, Art Tatum and George Shearing in his 'Jess Stacey' period, simply do not work pedalled 'even-power' - you absolutely have to give the little grace notes and shakes (passing tremolo chords) their proper softness. I am bound to say too that John Farrell has done Art Tatum a favour by ensuring that his more rococo keyboard excursions end, as they often in practice did not, on the beat. These are rolls worth having but only a few pretend to completeness and I admit to finding them insubstantial, a shortened taste of the original, a skilfully confected canapé of jazz. The Mike and Annie re-cuts, by the way, include some genuinely pleasing J. Lawrence Cook compositions of the 1920s, before his curious adoption around 1931 of that inescapable cod-Dixieland 'QRS sound' that lasted till his death. Schwimmer does not market his rolls like an ordinary dealer, however. A fixed number are made and are

offered for two or three months to subscribe to his postal auction. Any left over are put in small numbers without any great fanfare in later auctions. You have to be alert!

Back now to England, where Mike Boyd using the former Artona and Ambassador roll-cutting machine has been building up a big list of popular titles, mostly inherited on computer disk from Autoplayer of Slough, and under the Perforetur label, classics entered on to disk by Rex Lawson.

Technically, Boyd output is far better finished than Ambassador. The Slough 'bequest' includes some good music, too, including a pensive jazz medley by Laurie Holloway, but some share with many Slough rolls an uncertainty of attack, a seeming lack of grasp of the piece. To what degree this is thanks to the Slough recording piano and original computer recording accuracy, editors' interventions or your critic's faulty ear is impossible to say. Mike has done some new metronomic rolls on his own account, notably *Bach Goes To Town* (though the Benny Goodman lilt is missing) and a very fine *Stardust* arrangement.

The situation with Perforetur titles seems likely to spark off a debate about the whole subject of classical music on the pianola and how it should be promoted. Rex Lawson's transcriptions from music are beyond reproach. He has given the pianola world a complete set of Holst's *The Planets* for the first time and Lutoslawski's two-piano *Variations on a Theme of Paganini*. A three-roll set of Rachmaninov's *Rhapsody* on the same is paced easily for steady playing the way the composer liked it with expert 'theming' putting in the orchestral counterpoint while the pianolist's feet attend to the basic metre. But Mike Boyd is finding that popular titles sell ten to classical's one, and hand-played classical ten to one cut from music. Are rolls cut from score therefore an obsession of a small élite and not the way to spark off wider interest?

Here I return to my opening remarks: the hand-played roll does reach out to meet the player. Sooner or later that particular treatment will come to seem unsatisfactory and it is then with knowledge of the piece the experienced pianolist begins to value the uninterpreted version. What I do think is true is that neither the old companies nor present-day proselytisers for the pianola have properly addressed the business of awakening the huge potential of the classical pianola as a hobby, a joy and an education. It is here that the Institute could lead the field, while at the same time enhance its reputation, increase its support and boost its finances. A set of linked starter rolls and cassettes, maybe, demonstrating pianolists and pianists on the same piece? It's worth a thought.

Addresses:

BluesTone Music Rolls
240 North Ashland Avenue
Palatine
Illinois 60067
USA

Michael Boyd Music Rolls (Perforetur)
Unit 3
Mercatoria Business Centre
100 Norman Road
St Leonards on Sea
East Sussex TN38 OEJ
UK

Schwimmer's Piano Roll Centre (Hot Piano Classics)
325 East Blodgett
Lake Bluff
Illinois 60044
USA

Southport Roll Company
c/o Frances Broadway
39 Sydner Road
London N16 7UF
UK

Contributors

JOHN FARMER enjoys the distinction of having persuaded a sceptical musical public of the artistic worth of the reproducing piano at a time when it was at its lowest ebb. Through his supervision of a superb series of piano roll recordings for the BBC in the early 1960s, the Ampico overnight became respectable again. He is a leading authority on the system in his knowledge of its catalogue and its musical and technical capabilities, and has written important critical articles in a number of specialist journals, notably for the British Institute of Recorded Sound (National Sound Archive).

DENIS HALL has for many years been an enthusiast of historic performance recordings both on piano roll and disc and in making them accessible to present-day music lovers. He has involved himself in the restoration and preparation of reproducing pianos for concerts and recordings and in the transfer of 78 rpm recordings to master tape for LP reissue. In recent years he has turned his attention increasingly to the pianola.

DAN WILSON is a keen and experienced pianolist, and a longstanding member of the Player-Piano Group. He has been instrumental in the development of the art of pianola playing to its present-day standard, not least by the enthusiasm he has shown for converting new musicians to the cause of the instrument.

PATRICK HANDSCOMBE is a professional loudspeaker designer and Duo-Art theoretician, who studied history at the University of Bristol. He has for many years been practically involved in the restoration of player-pianos for public use, and in particular designed and built his own 88-note push-up used for concerts in various European countries.

ROBERT MATTHEW-WALKER is well known in the world of classical recordings. He was director of Masterworks Europe for CBS and later head of the classical department of RCA Records in London. He has just published an important new biography of Edvard Grieg, which includes a complete listing of the composer's own piano roll recordings.

